

SPECIFICATION

GVW (Kg)	6000	7000	8500	12000			
Curb weight (kg)	2155	2215	2555	2854	2910	3550	3880

Whole vehicle main dimensions							
Overall dimensions (LxWxH) mm	5400x1925x2260	5960x1925x2260	5960x2275x2220	5950x2135x2292	6920x2136x2265	7440x2310x2470	8940x2310x2470
Chassis length mm	3755	4315	4315	4315	5235	5453	6895
Internal length of cargo box mm	3600	4170	4170	4170	5140	5600	6750
Cabin Type	1880 Single cab		2060 Single cab			2060 Space cab	
Wheel base (mm)	2800	3360		3800	4200	5200	
Persons in cab (persons, 65kg)	3						

Power							
Engine	Model	ISF2.8s3148T		ISF3.8s3154		ISF3.8S3168	
	Fuel type	Diesel					
	Displacement(L)	2.78		3.76		3.76	
	Max. Power(Hp/rpm)	150/3200		156/2600		170/2600	
	Max. Torque(N · m/rpm)	360/1800-2700		500/1200-1900		600/1300-1700	
Transmission	Technology type	Electronic control high-pressure common rail					
	Exhaust emission standard	Euro III					
	Manufacturer	Cummins					
	Model	5S368	65500		65600		65600
	Technology type (Manu/Auto)	5MT		6MT		6MT	
Clutch	Torque	360		500		600	
	Speed ratio	I:5.762 II:2.922 III:1.638 IV:1.000 V:0.782 R:5.149		I:6.198 II:3.287 III:2.025 IV:1.371 V:1.000 VI:0.780 R:5.681			
	Manufacturer	ZF					
		Monolithic dry diaphragm spring φ308 × φ190					
Max. speed (km/h)	120 ≤						
EBP	•						
Cruise	•						
Electrical power supply	12V	•				24V	•

Chassis								
Axle	Front	Type	2.4T		2.5T		2.8T	3.6T
		Tonnage	2.4		2.5		2.8	3.6
	Rear	Type	Stamping and welding Integral type					
Suspension system	Front	Type	Non-independent suspension with spring					
		Spring	3					
	Rear	Type	Non-independent suspension with spring					
Steering system	Rear	Type	5+2				8+6	
		Spring	Round ball					
Oil supply system	Fuel tank material	Aluminum alloy						
		Fuel tank volume (L)	08	120	120	160	160	200
Tyre	Type	7.00R16	7.00R16	7.00R16	7.50R16	7.50R16	8.25R20	
		Number	6+1					
	Brake system	Brake type	Hydraulic		Air			
		Front	Disc		Disc			
		Rear	Drum		Drum			
Safety Device	Parking brake	Central drum brake		Air-cut brake				
	Exhaust brake	•						
Body and Interior	Seats	Fabric seat						
		Driver seat front and rear adjustable (manual)						
Windows	Rear-view mirror	•						
		Lock	Space bed					
Safety	Safety belts		•					
		Three-point seat belts (driver's seat)						
Comfort	Air-condition	•						
		Warm and cold (= warm air + air conditioning) manual						
Media equipment	MP3: FM / AM radio, USB / AUX	•						
		•						

MASS & DIMENSION

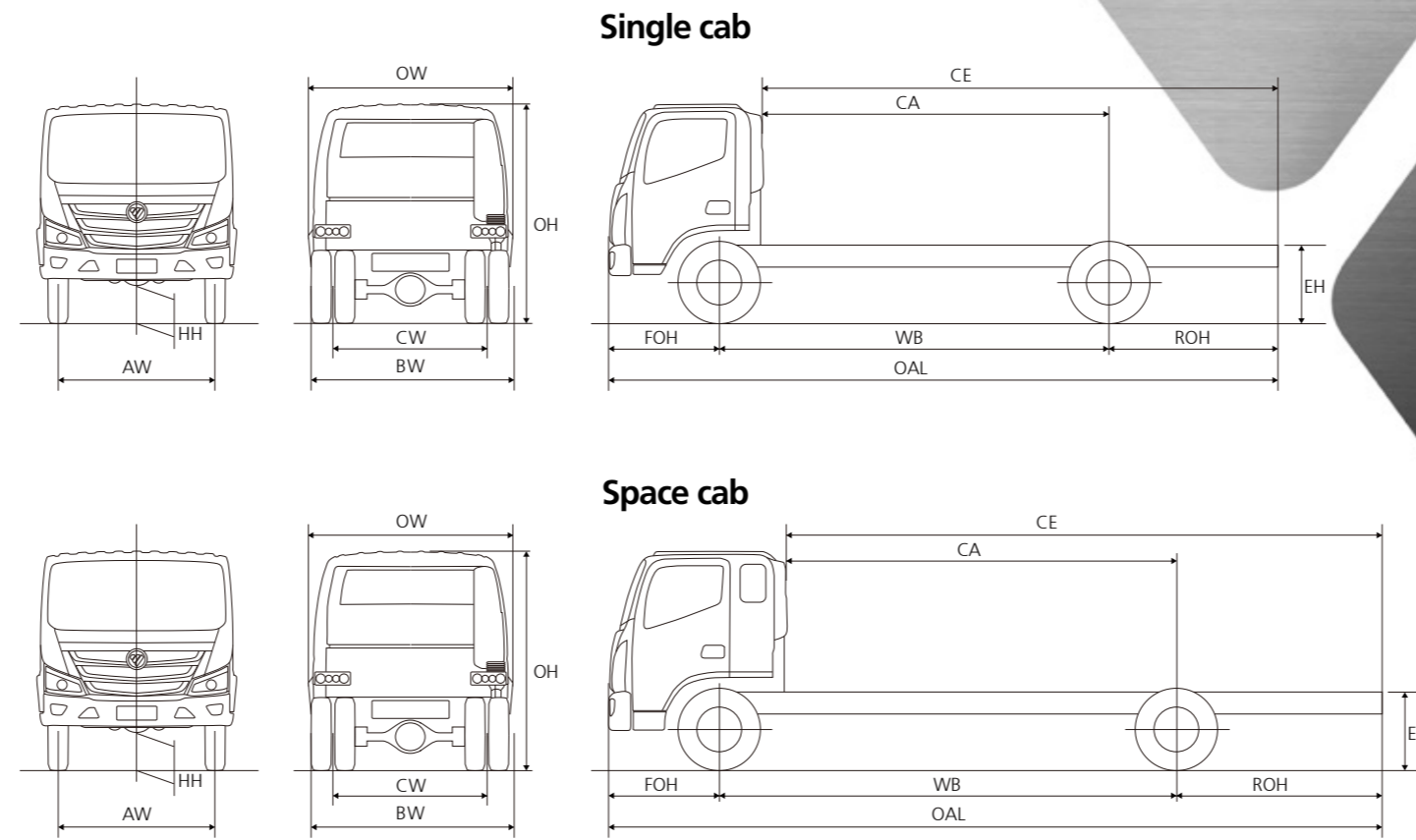

GVW (Kg)	Model	WB	OAL	OW	OH	AW	BW	CW	FOH	ROH	CA	CE	HH	EH
6000	BJ1065VDJD4- F	2800	5400	1925	2260	1590	1925	1485	1110	1490	2265	3755	190	708
	BJ1065VDJD6- F	3360	5960	1925	2260	1590	1925	1485	1110	1490	2825	4315	190	708
7000	BJ1068VDJDA- F	3360	5960	2135	2260	1730	2090	1615	1110	1490	2825	4315	190	708
	BJ1088VFJEA- F	3360	5950	2135	2260	1730	2090	1615	1110	1490	2825	4315	225	750
8500	BJ1088VEJEA- F	3800	6920	2135	2260	1730	2090	1615	1110	2010	3225	5235	225	750
	BJ1128VKJED- F	4200	7440	2310	2470	1792	2305	1800	1225	2015	3438	5453	227	983
12000	BJ1128VKPEK- F	5200	8940	2310	2470	1792	2305	1800	1225	2515	4380	6895	227	983

© MORE BODY APPLICATIONS



**EUROPEAN STANDARD
LOGISTIC EXPERT**

AUMARK S



For more information, welcome to scanning the QR code to visit the official website and social media pages in Saudi Arabia.
Petromin is the official exclusive distributor of Foton in Saudi Arabia
Petromin-foton.com • Tel: 920022919 • Email: foton@petromin.com

